

SAFETY GUARD CLOSED CONDITION

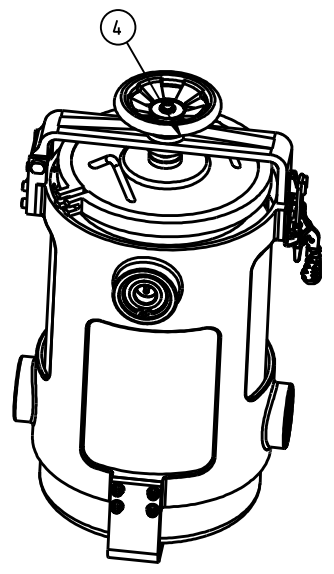

CAGE WITH CENTRE CLAMPING DEVICE

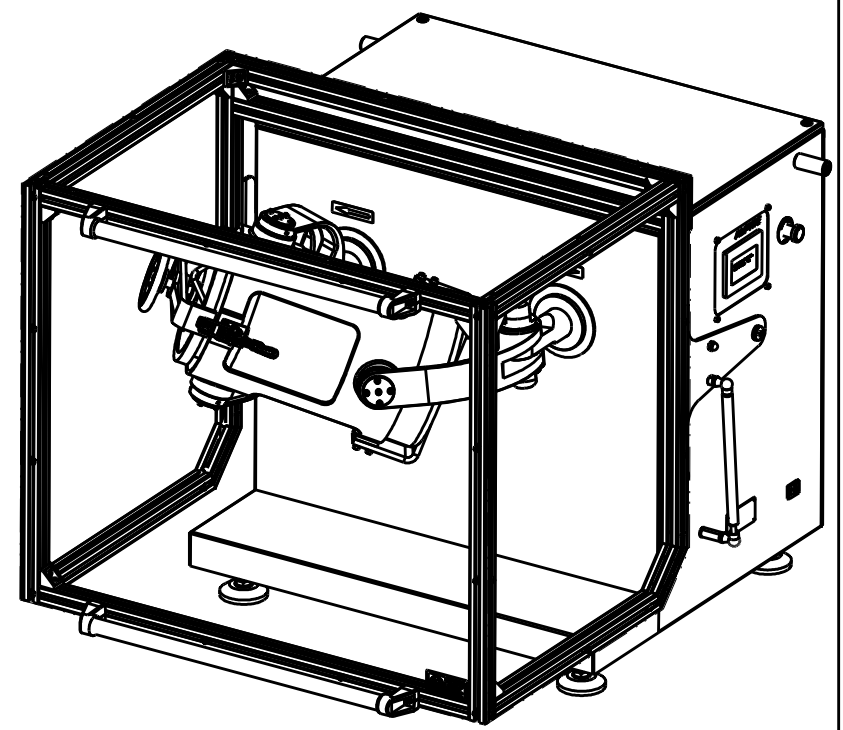
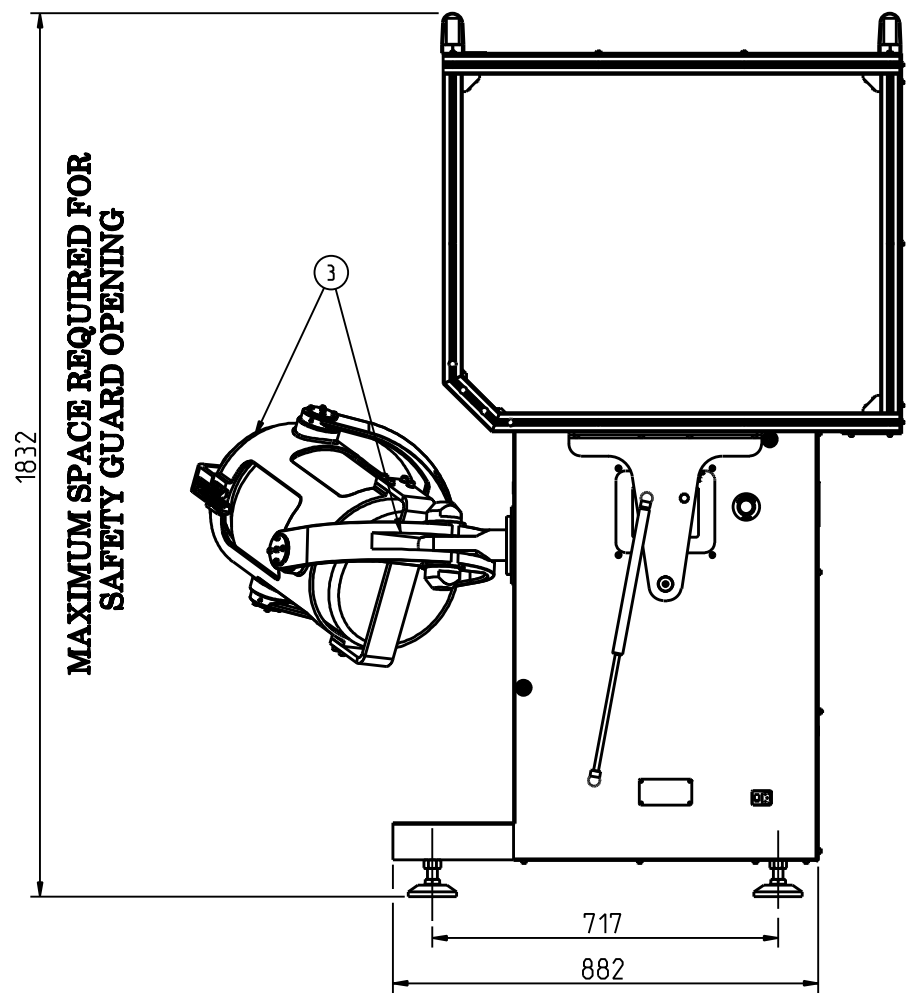

SAFETY GUARD OPENED CONDITION

NOTE:
 1. ALL OPEN DIMENSIONS TOLERANCE ARE WITHIN ± 20 MM.
 2. PLACE THE MACHINE ON LEVELLED STURDY SURFACE.

UTILITY REQUIRED		
01	POWER SUPPLY	220-240V. SINGLE PHASE. 50 Hz \pm 5%
02	CABLE SIZE	3 CORE CABLE WITH SOCKET. 2.7 MTR LENGTH
DESIGN DATA		
	MAX. CONTAINER SIZE	OD 305 X 533 LENGTH
	MAX. PRMISSIBLE LOAD	35 KG
	GROSS VOLUME CAPACITY	35 LTR.
	CAGE SPEED	VARIABLE FROM 10 TO 60 RPM MAX. WITH VARIABLE FREQUENCY DRIVE
8	CONTROL PANEL	PLC BASED IN-BUILT CONTROL PANEL WITH EMERGENCY STOP BUTTON
7	COVERS	PLAIN CARBON STEEL WITH POWDER PAINTED
6	MOUNTING LEGS	ANTI VIBRATION MOUNTS
5	SAFETY GUARD WITH INTERLOCK	MADE FROM ALUMINIUM PROFILE COVERED WITH PLEXIGLASS.
4	CONTAINER TIGHTENING	CENTRE CLAMPING DEVICE
3	CAGE WITH ARM	GRADED ALUMINIUM CASTING
2	DRIVE	HIGH EFFICIENCY GEARBOX WITH PULLEY DRIVE. WITH ANTI-FRICTION ROLLER BEARINGS
1	MOTOR	AC BRAKE MOTOR- 1 HP. 4 POLE
SR. NO.	DESCRIPTION	DETAIL

THIS DRAWING & DESIGN IS THE PROPERTY OF HEXAGON PRODUCT DEVELOPMENT PVT. LTD. AND MUST NOT BE COPIED OR LENT WITHOUT THEIR PERMISSION IN WRITING.

Rev. Letter	Revision	Rev. by	Chd. by	Appr. by	Date
TITLE: GENERAL ARRANGEMENT OF ALPHIE-35 (230 V)					
CLIENT:			MATERIAL: ..	WEIGHT: 375 kg	
SCALE: 1:10		Drawn: ARP	01-Mar-23	FIRST ANGLE	
		Check: GJV	01-Mar-23		
		Appr: HEXAGON	01-Mar-23		
HEXAGON PRODUCT DEVELOPMENT PVT. LTD. VADODARA			DRAWING NO. HA_035_23A014	SHEET 1 of 1	REV. 0