

**SAFETY GUARD OPENED CONDITION**

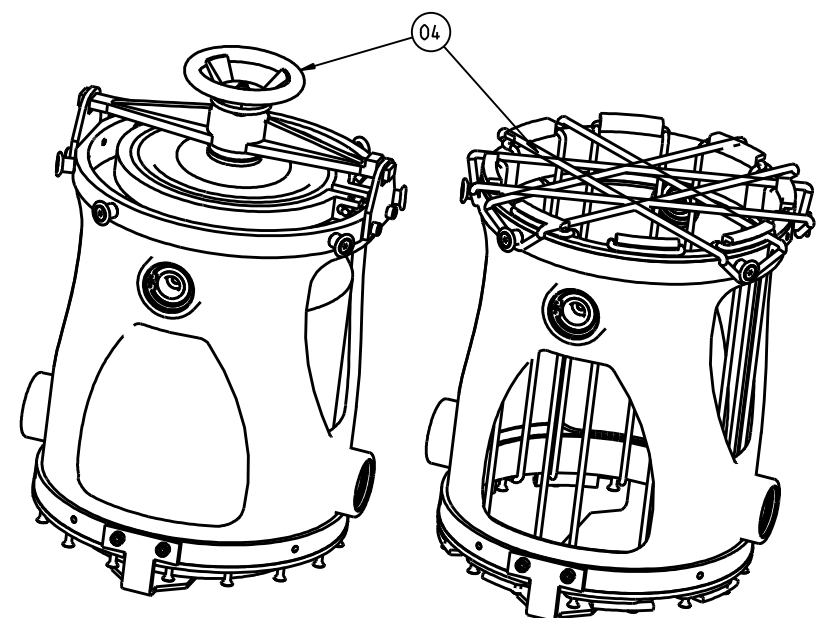

**CAGE WITH CENTRE CLAMPING DEVICE**      **CAGE WITH TENSIONING RUBBER STRING**

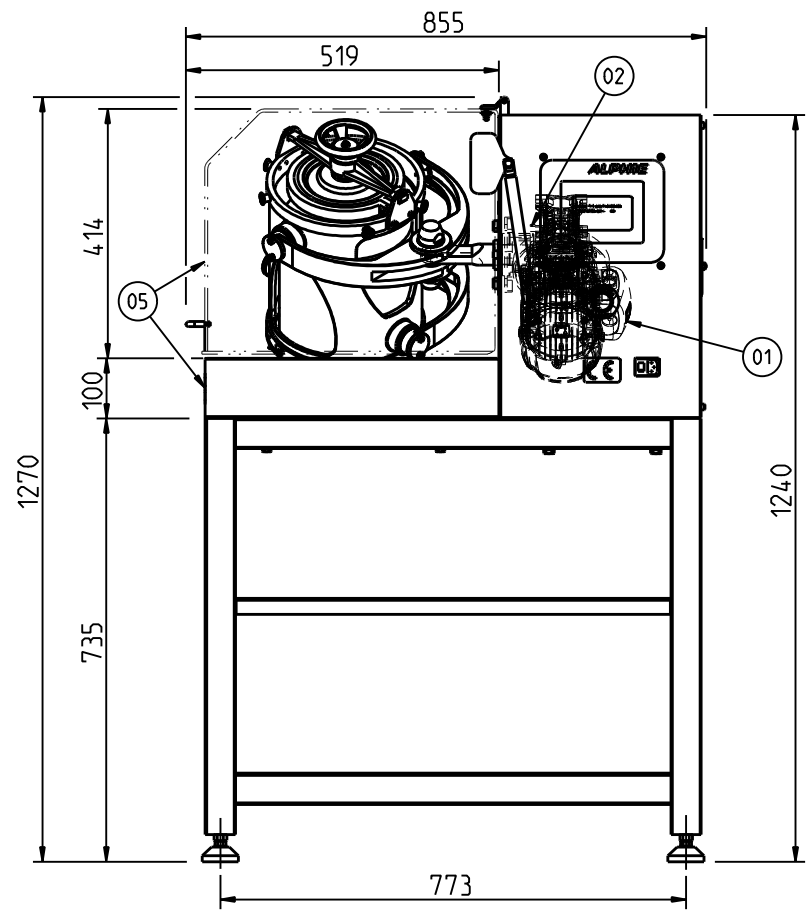

**SAFETY GUARD CLOSED CONDITION**

**NOTE:**  
 1. ALL OPEN DIMENSIONS TOLERANCES ARE WITHIN  $\pm 20$  MM.  
 2. PLACE THE MACHINE ON LEVELLED STURDY SURFACE.

UTILITY REQUIRED		
01 POWER SUPPLY	220-240 V. SINGLE PHASE. 50 Hz $\pm$ 5%	
DESIGN DATA		
MAX. CONTAINER SIZE	OD 220 X 340 LENGTH	
MAX. PERMISSIBLE LOAD	15 KG	
GROSS VOLUME CAPACITY	10 LTR	
CAGE SPEED	VARIABLE FROM 10 TO 70 RPM MAX. WITH VARIABLE FREQUENCY DRIVE	
BOM		
10 HAND TOOL	KEPT ON FRONT LEFT SIDE	
09 CABLE	3 CORE CABLE WITH SOCKET. 2.7 MTR LENGTH	
08 CONROL PANEL	PLC BASED IN-BUILT CONTROL PANEL WITH POSITION SENSOR AND EMERGENCY STOP BUTTON	
07 COVERS	PLAIN CARBON STEEL WITH POWDER PAINTED	
06 MOUNTING LEGS	ANTI VIBRATION MOUNTS	
05 SAFETY GUARD WITH TRAY	GUARD: PLEXIGLASS TRAY: PLAIN CARBON STEEL WITH POWDER PAINTED	
04 CONTAINER TIGHTENING	1. CENTRE CLAMPING DEVICE AND LOWER SUPPORT 2. TENSIONING RUBBER STRING ARRANGEMENT	
03 CAGE WITH ARM	GRADED ALUMINIUM CASTING	
02 DRIVE	HIGH EFFICIENCY WORM GEARBOX WITH ANTI-FRICTION ROLLER BEARINGS	
01 MOTOR	AC MOTOR- 0.5 HP. 4 POLE	
SR. NO	DESCRIPTION	DETAIL

Rev. Letter	Revision	Rev. by	Chd. by	Appr. by	Date
<b>TITLE:</b> <b>GENERAL ARRANGEMENT OF ALPHIE-10 (240V)</b>					
<b>CLIENT:</b>					
MATERIAL: ..      WEIGHT: 157 kg					
SCALE: 1:8					
Drawn: ARP      10-Feb-23					
Check: GJV      10-Feb-23					
Appr.: HEXAGON      10-Feb-23					
DRAWING NO. HA_010_23A006					SHEET 1 of 1 REV. 0

THIS DRAWING & DESIGN IS THE PROPERTY OF HEXAGON PRODUCT DEVELOPMENT PVT. LTD. AND MUST NOT BE COPIED OR LENT WITHOUT THEIR PERMISSION IN WRITING.