

DO NOT SCALE THE DRAWING

IF IN DOUBT, PLEASE ASK

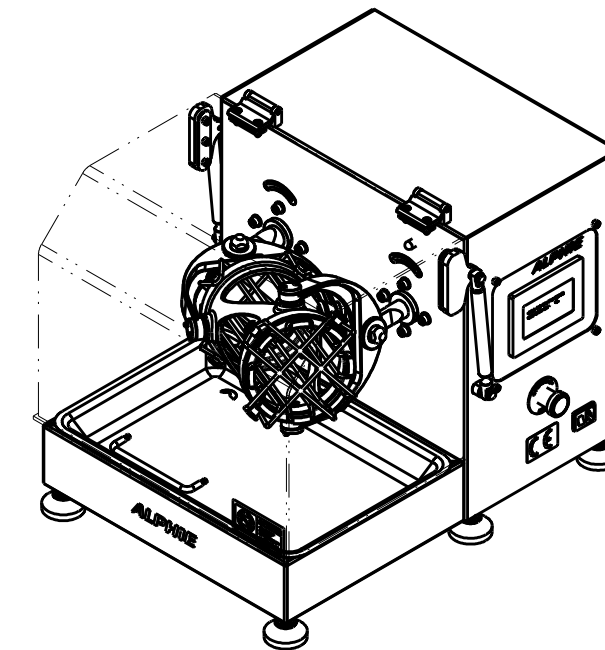
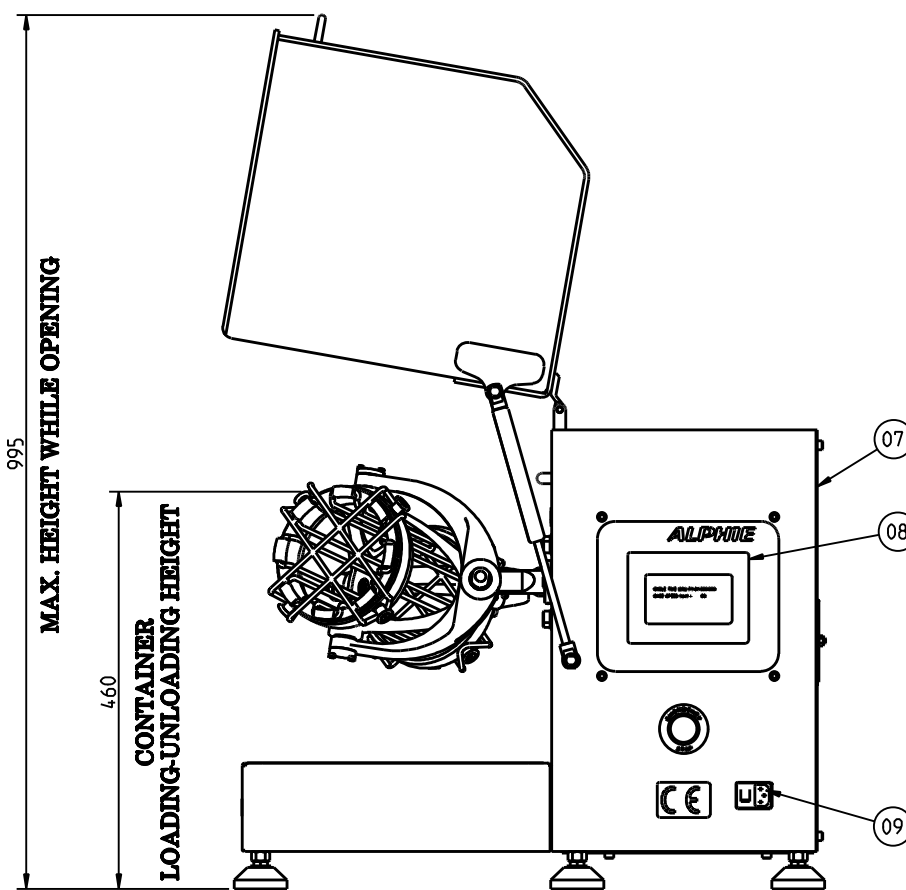
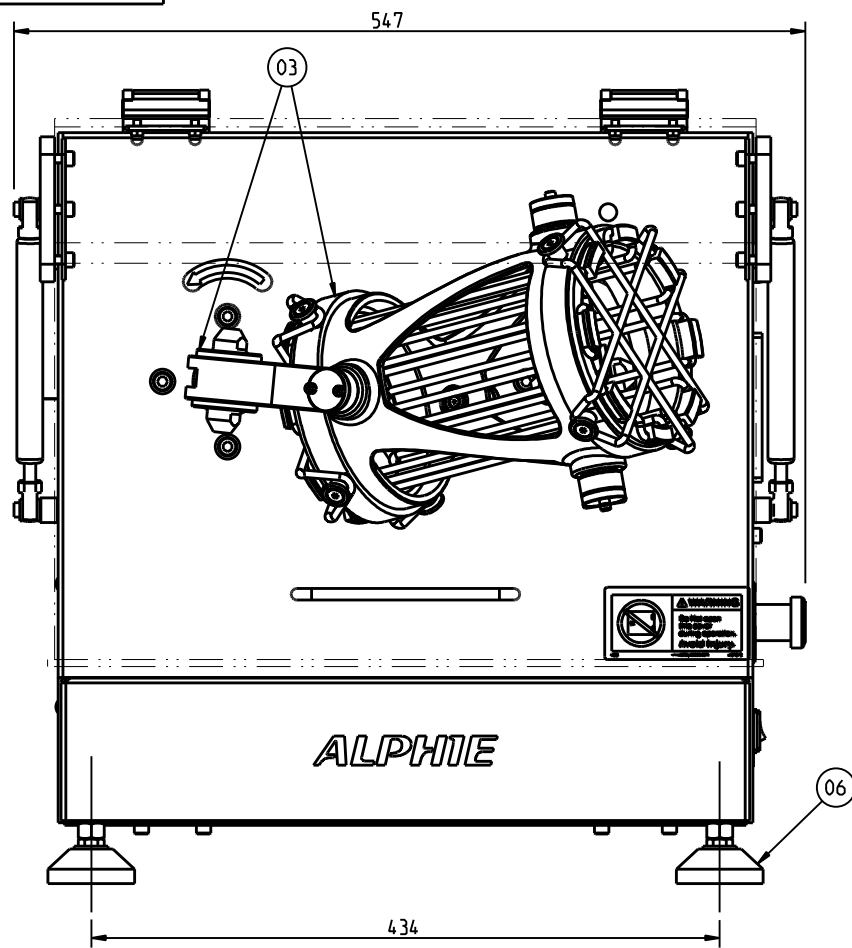

SAFETY GUARD OPENED CONDITION

NOTE:
 1. ALL OPEN DIMENSIONS TOLERANCES ARE WITHIN ± 20 MM.
 2. PLACE THE MACHINE ON STURDY AND LEVELLED PLATFORM.

UTILITY REQUIRED	
01 POWER SUPPLY	220-240 V. SINGLE PHASE. 50 Hz \pm 5%
DESIGN DATA	
MAX. CONTAINER SIZE	OD 115 X 280 LENGTH
MAX. PERMISSIBLE LOAD	5 KG
GROSS VOLUME CAPACITY	2.5 LTR
CAGE SPEED	VARIABLE FROM 10 TO 80 RPM MAX. WITH VARIABLE DRIVE FREQUENCY
09 CABLE	3 CORE CABLE WITH SOCKET, 2.7 MTR LENGTH
08 CONTROL PANEL	TOUCH SCREEN HMI WITH PLC BASED IN-BUILT CONTROL PANEL WITH POSITION SENSOR AND EMERGENCY STOP BUTTON
07 COVERS	PLAIN CARBON STEEL WITH POWDER PAINTED
06 MOUNTING LEGS	ANTI VIBRATION MOUNTS
05 SAFETY GUARD WITH TRAY	UPPER GUARD - PLEXIGLASS TRAY - STAINLESS STEEL TRAY SUPPORT -PLAIN CARBON STEEL WITH POWDER PAINTED
04 CONTAINER TIGHTENING	USING CROWN AND SILICONE RUBBER STRING
03 CAGE WITH ARM	GRADED ALUMINIUM CASTING
02 DRIVE	HIGH EFFICIENCY WORM GEARBOX WITH ANTI-FRICTION ROLLER BEARINGS
01 MOTOR	AC MOTOR- 0.5 HP. 4 POLE
SR-NO	DESCRIPTION
	DETAIL

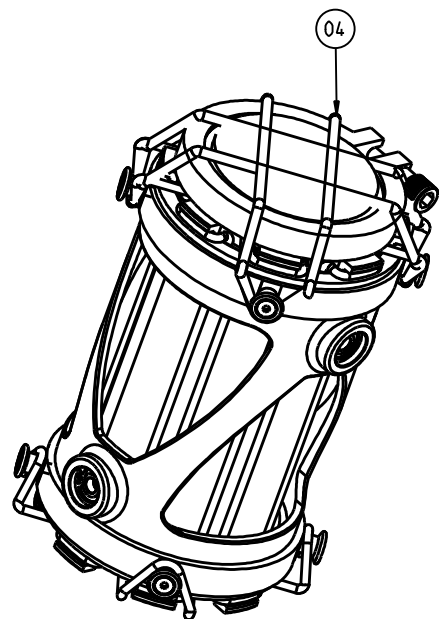

CONTAINER PLACED IN CAGE AND TIGHTENED USING RUBBER STRING

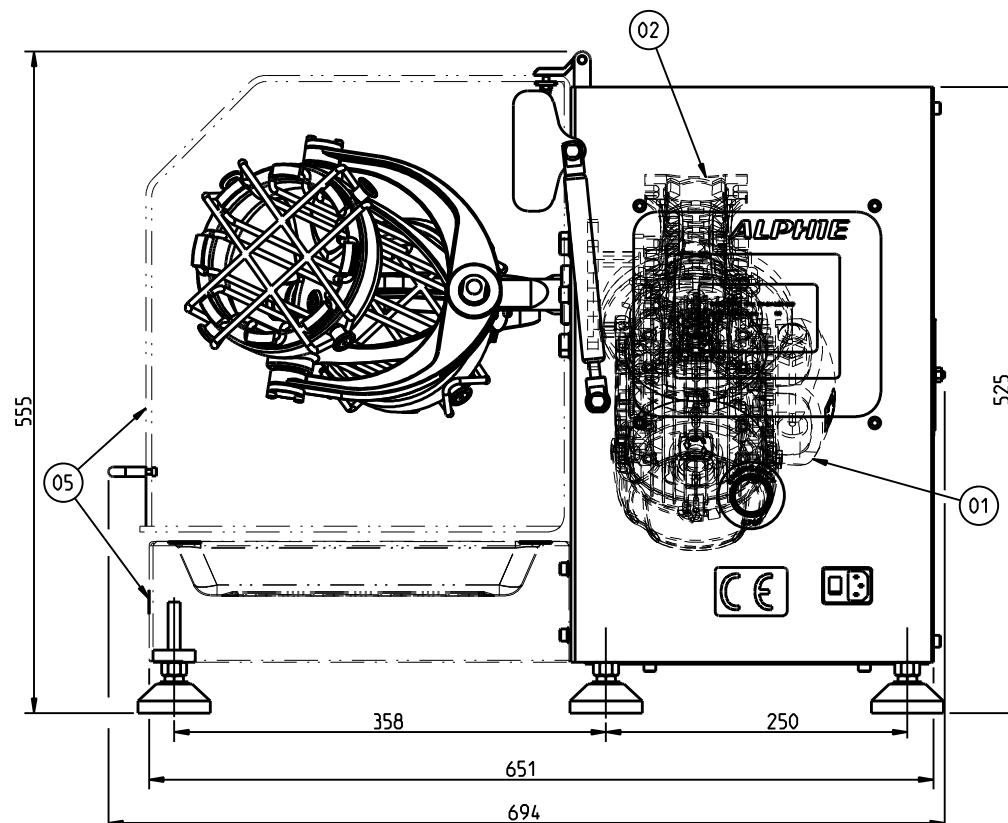

SAFETY GUARD CLOSED CONDITION

THIS DRAWING & DESIGN IS THE PROPERTY OF HEXAGON PRODUCT DEVELOPMENT PVT. LTD. AND MUST NOT BE COPIED OR LENT WITHOUT THEIR PERMISSION IN WRITING.

Rev. Letter	Revision	Rev. by	Chd. by	Appr. by	Date
TITLE: GENERAL ARRANGEMENT OF ALPHIE-3 (240V)					
CLIENT: -					MATERIAL: .. WEIGHT: 69 kg
SCALE: 3:10					Drawn: ARP 10-Feb-23 Check: GJV 10-Feb-23 Appr.: HEXAGON 10-Feb-23
HEXAGON PRODUCT DEVELOPMENT PVT. LTD. VADODARA					DRAWING NO. HA_003_23A002 SHEET 1 of 1 REV. 0