

**MIX
THE IMPOSSIBLE
TO
PERFECTION**

ALPHIE®
Three Dimensional Mixer

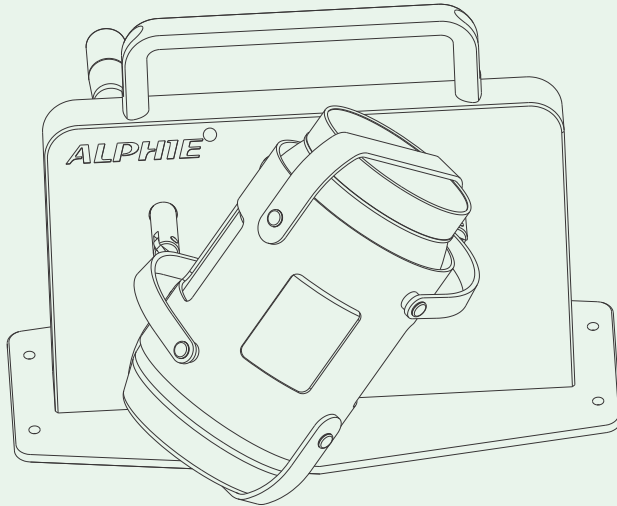

HAINDIE

WORLD'S BEST MIXING TECHNOLOGY
IN
YOUR HAND

What is Alphie mixer

The motion of Alphie mixer is based on the kinematic inversion (Paul Schatz) principle. The unusual, three dimensional mixing motion quickly and efficiently produces a homogeneous substance regardless of specific weight of the substances being mixed. This makes it an ideal powder blender or liquid mixer.

Manual Alphie Mixer brings same technology power to you - generating rhythmic and pulsating movement controlled naturally by your hand. Added with the mobility!

Specific Features

- ◆ Can accommodate up to 2.0 Ltr container and up to 3 kg of mixture
- ◆ Mixing containers are separate and removable. No question of cross contamination / cleaning or waiting time. Just Remove the container and mixer is ready for next cycle.
- ◆ Ability to fit any smaller shape / size of container and with different material of construction.
- ◆ Simple to use - effortless fixing of the container using silicone bands. No tools needed.
- ◆ No use of powder coated carbon steel. All exposed steel parts are stainless steel grade AISI 304.
- ◆ All joints are fitted with maintenance / lubrication free bearings.

OUR OTHER MODELS - RANGING FROM 3 LTR TO 1500 LTR

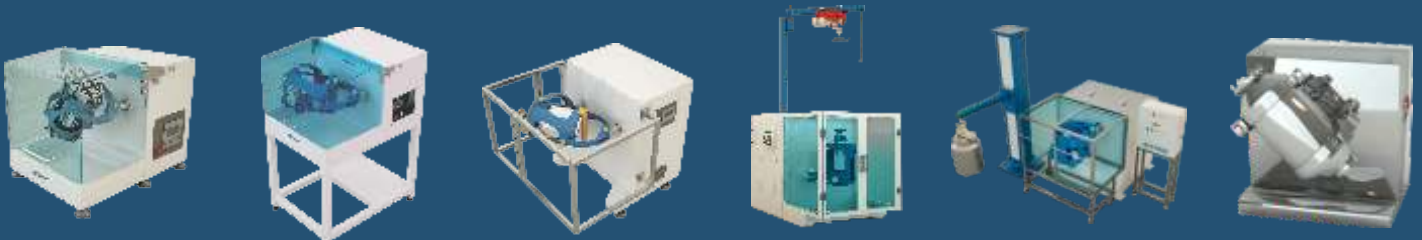

Specification

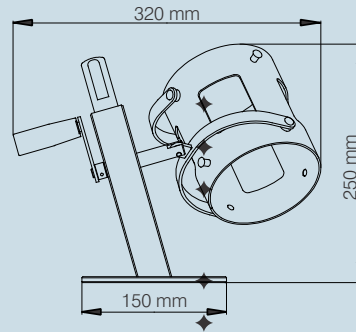
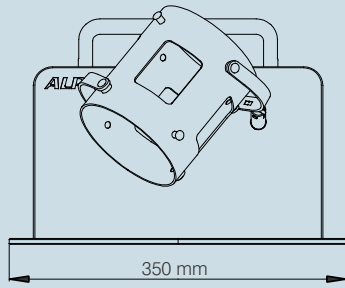

Max container capacity - 2.0 Ltr

Max container can be fitted - Dia 115 mm x 210 mm Long

Max permissible mixing mass - 3.0 kg

Mixer weight - 9.0 kg

Mixer is supplied with 01 no. 2.0 Ltr PET bottle

Optional Accessories

- ◆ Attachment to fix any smaller shape container
- ◆ Mixing balls of stainless steel or tungsten carbide of various diameter
- ◆ Mixing container of stainless steel / Glass / plastic
- ◆ Fasteners to fix mixer on table permanently
- ◆ Fixing clamp to grip with table top
- ◆ Spare rubber straps

Contact us for details.

Mixing Benefits

- ◆ Quick mixing and homogeneity across varieties of bulk density / particle shape and size difference
- ◆ Mixing Motion is not of rotation. It's inversion. So no centrifugal force on particle and so no local heating and particle separation
- ◆ Gentle mixing without any shear force on substances
- ◆ Dust free hygienic mixing in closed container

Mixing Guideline

- ◆ Do gentle mixing with speed of 40 to 50 revolution by hand
- ◆ Caution - It's a myth that high speed mixing or mixing for longer duration is always good. Every application has its optimum time and speed to get best mixing quality. Overmixing creates churning effect and de mixes.
- ◆ Do not fill container more than 60% of volume for powder mixing. Mixing time increases exponentially with less empty volume. Allow good amount of space for substance to move freely. Of course, for liquids it can be filled 80% also.
- ◆ Use balls to break lumps, if application demands.

For use in

- ◆ R & D Laboratories
- ◆ Educational Institutes
- ◆ Small batch production industry
- ◆ Food, Nutrition and Pharmaceuticals
- ◆ Metal powder, Resin and plastic powder
- ◆ Restaurant, Bars and kitchens
- ◆ Bakery, spices, concentrates and many more

About Us

Hexagon - started as New product design & development centre in 2001, is ISO 9001:2015 certified company in Design and manufacturing of Alphie mixers. We offer mixing solution across the globe with focus on innovative customisation.

Global Customer Base

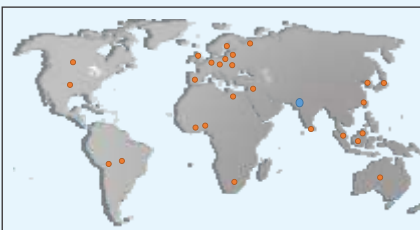

For more details contact us at :-

HEXAGON PRODUCT DEVELOPMENT PVT. LTD.

Ratnakar Business Hub, Plot No 10, Por Ramangamdi Road,
GIDC, Por - 391 243, Vadodara, INDIA. Phone : +91 70430 86111
E-mail : info@alphiemixer.com, URL : www.alphiemixer.com

* We reserve the right to change content, picture & specification as per continuous research & development.



DSIR (Govt. of India)
recognised R & D Centre